

ERGOFUNK Basic

2 LEG / 2 MOTOR
40x20

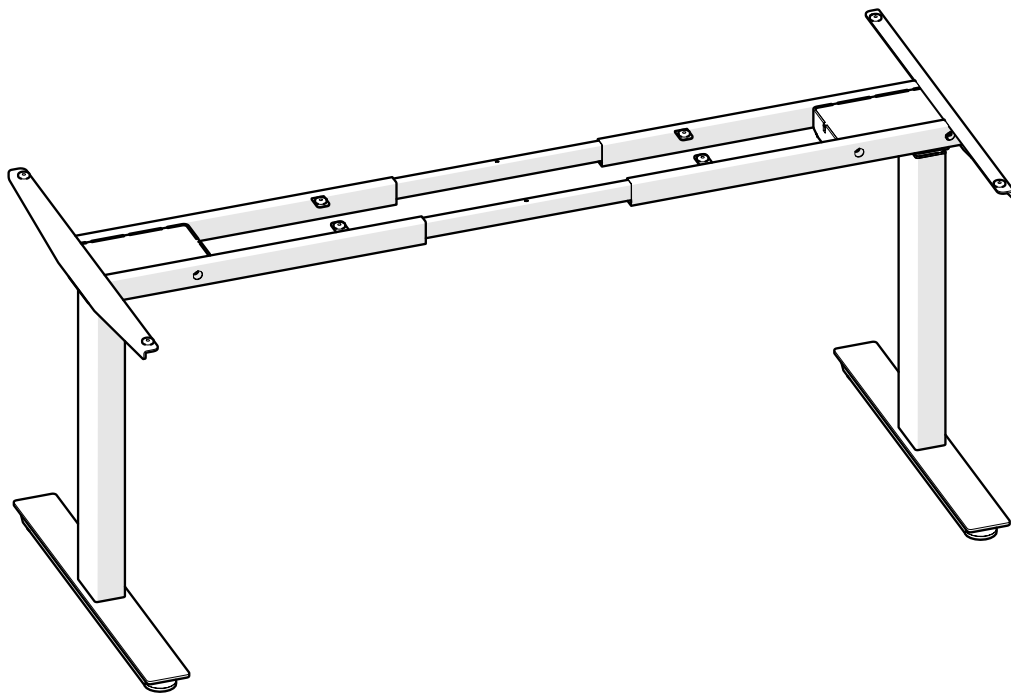

Table of contents

1. General

- 1.1 Local value of the user manual
- 1.2 Intended use

2. Safety Information

- 2.1 Informal safety measures
- 2.2 Use of the adjustable frame
- 2.3 Specific Dangers
- 2.4 In an emergency
- 2.5 Maintenance
- 2.6 Cleaning

3. Packaging

- 3.1 Part List
- 3.2 Screw List

4. Assembly

- 4.1 Torque Guide
- 4.2 Assembly Step by Step

5. Operating Instructions

- 5.1 Zero Setting
- 5.2 General Operation

6. Troubleshooting

- 6.1 Possible faults and remedies

1. General

1.1 Local value of the user manual

The guiding principle for safe use and trouble-free operation of this adjustable frame is the knowledge of basic safety information and regulations. This user manual includes the most important information needed for assembling and operating the adjustable frame safely. More importantly, the safety information about the adjustable frame must be observed at all times.

1.2 Intended use

The adjustable frame must be used only as a workstation for sitting / standing within the office environment or other indoor areas. Please observe the provision of section 2, Safety Information. Children may be unaware of the dangers caused by the adjustable frame if unsupervised. Any other use except the above should be considered improper. The manufacturer can in no way be held liable for damage arising from improper use.



Any changes or modification not expressly approved by the manufacturer could void the user's authority to operate the equipment.

2. Safety Information

When installing and using electrical equipment, basic safety precaution should always be followed to avoid a risk of fire, electric shock, or injury to persons.

2.1 Informal safety measures

- Keep the user manual in the place where the adjustable frame is used at all times.
- Keep children away from the appliance when operation.

2.2 Use of the adjustable frame

- When adjusting upwards and downwards, make sure that no persons or items will collide with the frame.
- Don't use the adjustable frame on an uneven surface, or it will not be steady.
- Never exceed the maximum load capacity on the adjustable frame. Please check the load capacity in Section 7, Specification.
- The control unit is only used for specified linear actuator, don't use appliances not recommended by the manufacturer.

2.3 Specific Dangers

- When assembling and operating the adjustable frame, make sure there is enough space to avoid collisions in all available directions.
- Don't pull, push or lift the frame if operating. Make sure to avoid twisting the legs.
- Insert the plug only into a proper socket. If it does not fit, contact a qualified electrician to install the proper outlet. Don't change the plug in any way.
- Be aware that the control box can only be connected to the voltage printed on the label.

2.4 In an emergency

- Stop using the adjustable frame immediately if you notice anything unusual (strange sounds etc.).
- The frame should be repaired by professional staff. Stop using the adjustable frame until it has been successfully repaired.
- Any other emergencies please contact customer services.

2.5 Maintenance

- The adjustable frame and its components are low-maintenance items and need no special regular maintenance.
- Any broken components removed must be replaced with new, original components made by the manufacturer.
- Don't alter the construction of the adjustable frame.

2.6 Cleaning

- Clean the frame once a week with a dry cloth.
- Clean the frame with a damp cloth and a weak solution of cleaner once every two weeks.

3. Packaging

3.1 Part Check List

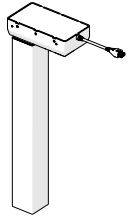

Leg (2 Pcs)

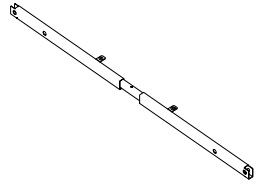

Frame (2 Pcs)

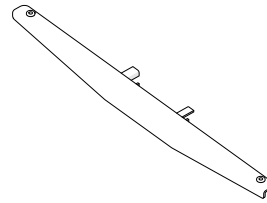

End Pipe (2 Pcs)

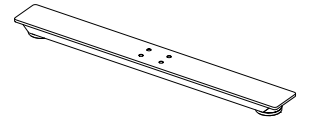

Feet (2 Pcs)

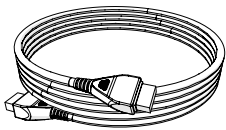

Connection Cable (1 Pcs)

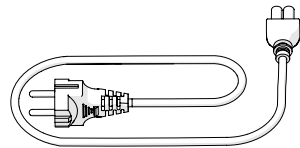

Power Cable (1 Pcs)

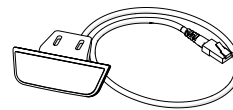

Remote Control (1 Pcs)

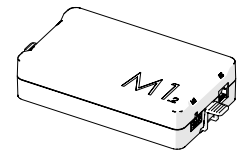

Control Unit (1 Pcs)

3.2 Screw List



ST 2.9x16 (2 Pcs)



ST 4.2x16 (2 Pcs)

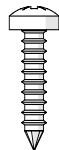

ST 4.8x19 (8 Pcs)

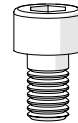

M6x12 (12 Pcs)



M6x16 (8 Pcs)



Before attempting assembly of the Height Adjustable Frame, please read safety information in Section 2.

Torque Guide

Max torque

- M6 Screw's max torque = 6nm
- M8 Screw's max torque = 6nm
- M10 Screw's max torque = 6nm
- **Tapping screws is hand tightening only**



Parts displayed above may vary, based upon Frame Configuration

4. Assembly

4.2 Assembly Step by Step

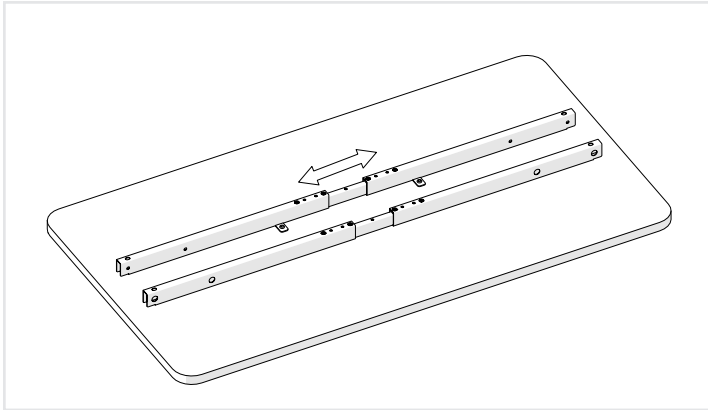

Step 1
Adjust Top Frame to suitable length.

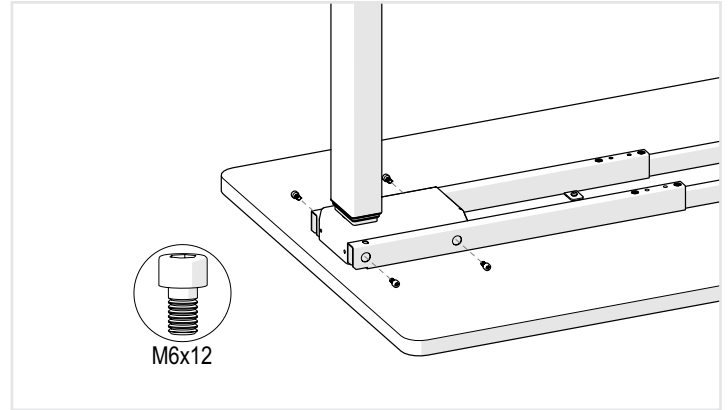

Step 2
Assemble the Leg and Frame as illustrated above. Please refer to **Torque Guide**.

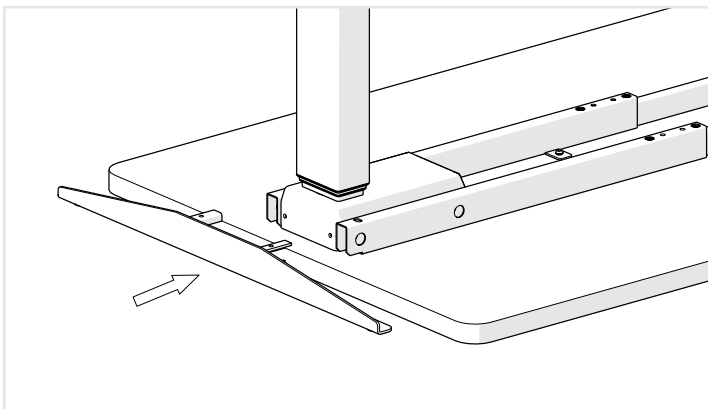

Step 3
Mount the End Pipe as illustrated above.

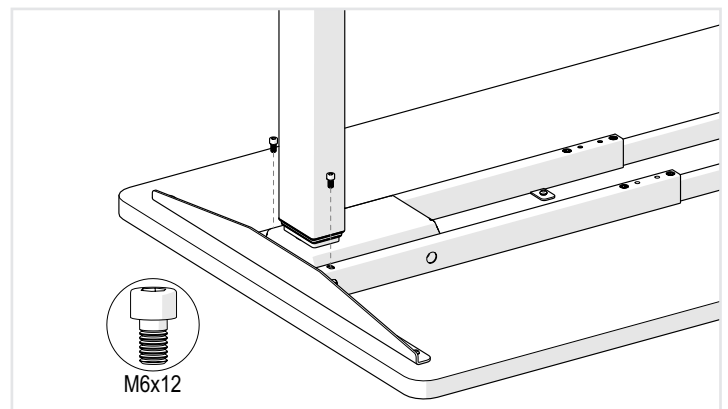

Step 4
Assemble the End Pipe and Frame as illustrated above. Please refer to **Torque Guide**.

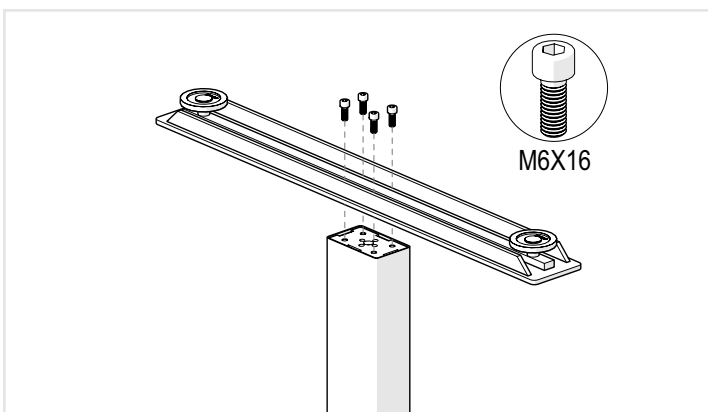

Step 5
Mount the Feet as illustrated above. The smooth side of the plate faces the foot. Please refer to **Torque Guide**.

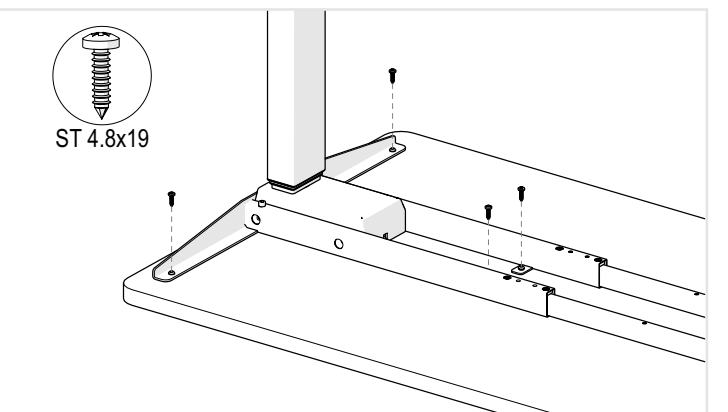

Step 6
Mount the Frame and End Pipe to the Table top as illustrated above. Please refer to **Torque Guide**.

4. Assembly

4.2 Assembly Step by Step

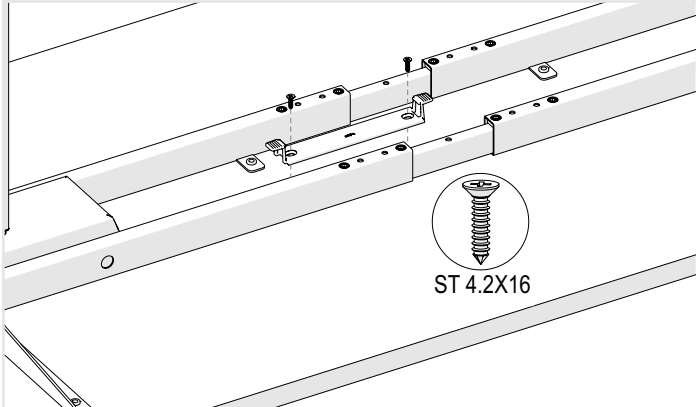

Step 7
Mount the Control Unit Bracket as illustrated above. Please refer to **Torque Guide**.

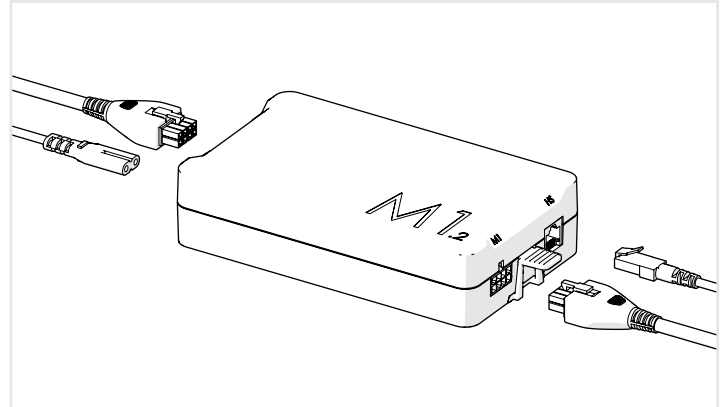

Step 8
Connect the Cables to the Control Unit as illustrated above.

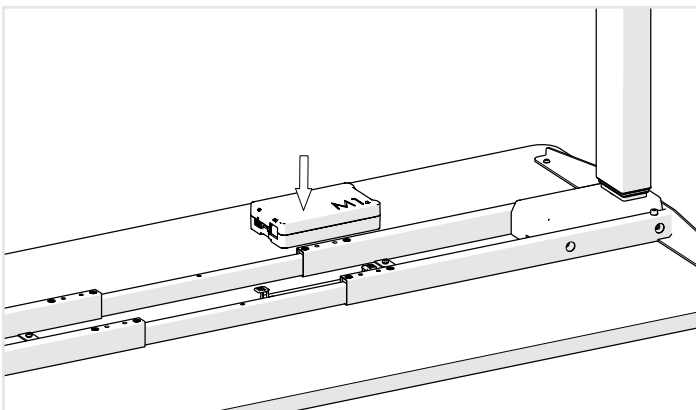

Step 9
Mount the Control Unit as illustrated above.

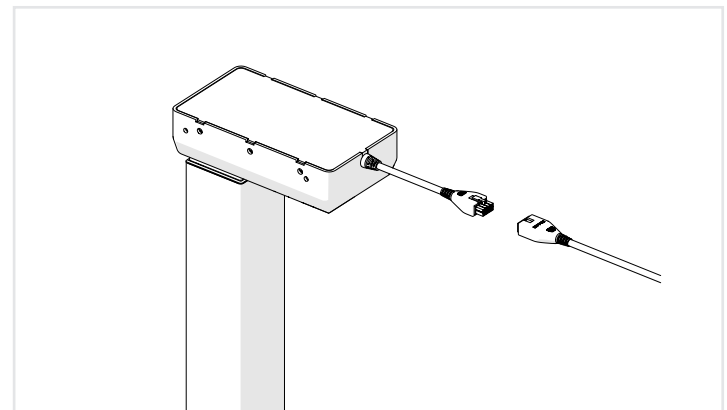

Step 10
Connect the Connection Cable to the Leg as illustrated above.

 **Do not put power to the system before it is fully assembled.**

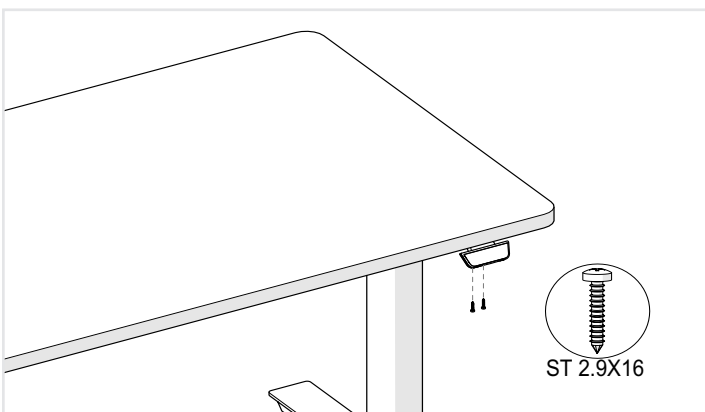

Step 11
Mount the Remote Control to the Table top as illustrated above. Please refer to **Torque Guide**.

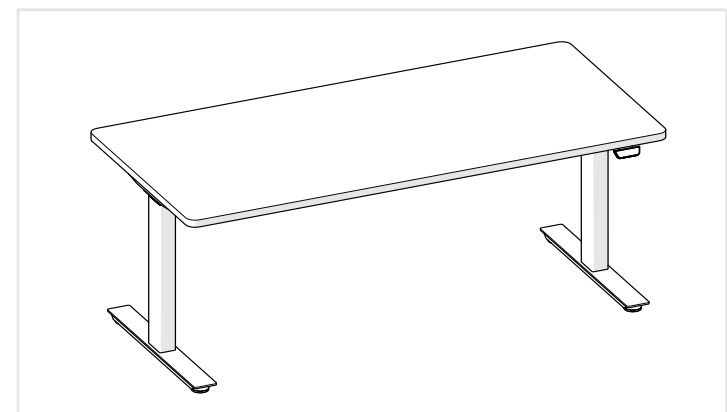

Step 12
Perform Zero Setting.

5. Operating Instructions

Please read below instructions carefully before operating the system.



Up



Down

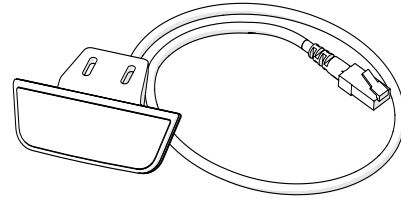

5.1 Zero Setting:

When using the height adjustable frame for the first time lower the desk to the lowest height as explained below before proceeding .

- Press ▼ button and keep pressing the button until the desktop has reached the lowest position (programmed desktop position).
- Press ▼ button again and hold. After about five seconds, the desktop will slowly move further down until it reaches the lowest possible desktop position.
- Release ▼ button. The electric height adjustable frame is now ready for use.



Zero setting position is approximate 5mm lower than original starting height position.

5.2 General Operation:

This function enables you to adjust the frame upwards or downwards.

Press ▲ or ▼ button and keep pressing the button until the required frame height is reached.



The frame will continue moving upwards or downwards until you release the button or the maximum / minimum height is reached.

5.3 Container and Shelf Stop position:

These two features can be used to limit the movement area of the desktop (e.g. if a container is placed underneath the desktop). A container stop position can be defined in the lower half of the movement area, a shelf stop position in the upper half. If a container stop position is set, this position will be the lower limit position. If a shelf stop position is set, this position will be the new upper limit position.

To store a container stop / shelf stop position, go on as shown below:

- Move the frame to the position where the container stop / shelf stop position shall be stored. Do so by pressing the ▼ or ▲ until you reach the desired position.
- Press both up and down button (▲ & ▼) for 10 seconds. The control unit will click twice when the container stop / shelf stop position is stored.



A container stop position can only be stored in the lower half of the movement area and a shelf stop in the upper half. These steps have to be done for a container stop and a shelf stop position separately!

To remove the container stop/ shelf stop position follow the instructions below:

- Move the frame to any position in the lower half to deactivate the container stop. Move the frame to any position in the upper half to deactivate the shelf stop. Do so by pressing the ▲ or ▼ button until you reach the desired position.
- Press both up and down button (▲ & ▼) for 10 seconds. The control unit will click once when the container stop / shelf stop position is deactivated.



These steps have to be done for a container stop and a shelf stop position separately!

6. Troubleshooting

In this section you will find detailed information on the following topics:

- Possible faults and remedies
- Error messages on the remote control display

6.1 Possible faults and remedies

Legs not working

Possible Cause

- ≡ Power Cable is not connected
- ≡ Legs are not connected
- ≡ Poor plug contact
- ≡ Control Unit is defective
- ≡ Remote Control is defective

Remedy

- ≡ Plug the Power Cable into the Control Unit
- ≡ Plug the Motor Cables into the Control Unit and Legs
- ≡ Check all connections
- ≡ Replace the Control Unit
- ≡ Replace the Remote Control

Legs only operating in one direction

Possible Cause

- ≡ Mains power breakdown or main power is plugged off during movement
- ≡ Control Unit is defective
- ≡ Remote Control is defective
- ≡ Leg is defective

Remedy

- ≡ Zero setting (if movement is only possible downwards)
- ≡ Replace Control Unit
- ≡ Replace the Remote Control
- ≡ Replace the Leg

Control Unit or Remote Control is not working

Possible Cause

- ≡ Power Cable is not connected
- ≡ Remote Control is not connected
- ≡ Control Unit is defective
- ≡ Power Cable is defective
- ≡ Remote Control is defective
- ≡ Poor plug contact
- ≡ Exposed to liquids

Remedy

- ≡ Plug the power cable into the control unit
- ≡ Plug in the remote control
- ≡ Replace the Control Unit
- ≡ Replace the Power Cable
- ≡ Replace the remote control
- ≡ Check all connections
- ≡ Replace the remote control